

USE AND MAINTENANCE MANUAL



WRITTEN BY REDIMEC S.r.l.
SETTIMO MILANESE (MI)

AIRLESS GUN MODEL : **K90**

(Rev. 1 - 12/04/2000)
GB - K90 - 1.0

ASTURO ORIGINALI MAVES Spa
Via F.lli Bandiera, 7
20090 Trezzano sul Naviglio (MI) ITALY

SINCERT



ISO 9001

Cert. -04985-99-AQ-MIL-SINCERT

DICHIARAZIONE DI CONFORMITÀ / DECLARATION OF CONFORMITY
KONFORMITÄTERKLÄRUNG / DECLARATION DE CONFORMITÉ
DECLARACIÓN DE CONFORMIDAD



ASTURO ORIGINALI MAVES Spa
Via Flli Bandiera, 7
TREZZANO S/N MILANO - ITALIA
++39 0248400326 - FAX ++39 0248402810
P.IVA / VAT (registration number) 11164500156



MODELLO / MODEL K 90

N_ di MATRICOLA / SERIAL NUMBER

ANNO DI COSTRUZIONE / YEAR OF MANUFACTURE 200

ACCESSORI IN DOTAZIONE / ACCESSORIES SUPPLIED

A.O.M spa DICHIARA sotto la sua esclusiva responsabilità che la macchina a cui la presente dichiarazione si riferisce è conforme alle prescrizioni delle seguenti direttive:

A.O.M spa DECLARES on its own responsibility that the machine to which this declaration refers conforms with the requirements in the following directives:

DIRETTIVA **89/392/CEE** MODIFICATA DALLA DIRETTIVA **91/368/CEE**
DALLA DIRETTIVA **93/44/CEE** E DALLA DIRETTIVA **93/68/CEE** (DIRETTIVA MACCHINE)
DIRECTIVE **89/392/EEC** AMENDED BY DIRECTIVE **91/368/EEC**
BY DIRECTIVE **93/44/EEC** AND BY DIRECTIVE **93/68/EEC** (MACHINE DIRECTIVE)

La macchina è inoltre conforme alle seguenti norme / The machine also conforms with following standards:

UNI EN 292/1 (november 1992) Sicurezza del macchinario, Concetti fondamentali, principi generali di progettazione.- Terminologia, metodologia di base
Machine safety, Fundamental concepts, General design principles - Terminology, basic methodology.

UNI EN 292/2 (november 1992) Sicurezza del macchinario - Concetti fondamentali, principi generali di progettazione - Specifiche e principi tecnici
Machine safety - Fundamental concepts. General design principles - Technical specification and principles.

LUOGO / PLACE:

TREZZANO S/N

COGNOME - NOME / SURNAME - NAME:

BRANCHINI RIZIERI

POSIZIONE / POSITION:

AMMINISTRATORE UNICO / SOLE DIRECTOR

DATA / DATE:

/ / /

FIRMA/SIGNATURE:.....

Dear Customer,

We want to thank you for choosing one of **ASTURO ORIGINALI MAVES Spa** products.

ASTURO ORIGINALI MAVES Spa is a leading reference point in the field of painting systems and machinery.

The name **ASTURO ORIGINALI MAVES Spa** has always meant reliability and safety and this is supported by over 70 years of experience and by our Customer satisfaction.

All our components have been designed and manufactured to guarantee the best performance ever.

To maintain the high quality level and lengthy reliability of our products throughout the years, always use original spare parts.

ASTURO ORIGINALI MAVES Spa units have the CERTIFICATION in accordance with EUROPEAN DIRECTIVE 89/392 (Machine Directive.)

We are certain we have met all safety requirements and we feel confident we have further improved working standards.

Our units, in fact, have the identification plate in accordance with  rulings. Furthermore, they are delivered with the instruction manual and the certificate with the Declaration of Conformity to European Directive 89/392 and to its various amendments.

The Management

GENERAL CONTENTS

HOW TO USE THE MANUAL.....	1
SYMBOLS USED.....	1
INFORMATION LETTER.....	2
1.1 PACKAGING.....	3
2.1 IDENTIFICATION DATA.....	3
2.2 EQUIPMENT DESCRIPTION.....	4
2.3 TECHNICAL FEATURES.....	5
2.4 STANDARD AND OPTIONAL COMPONENTS.....	5
2.5 PAINTS, FLUIDS AND ADEQUATE PRODUCTS.....	6
2.6 DIMENSIONS.....	6
3.1 INSPECTION OF PURCHASED PRODUCT.....	7
3.2 INSTALLATION CONDITIONS.....	7
3.3 EQUIPMENT AND CONDITIONS NEEDED TO WORK.....	7
3.4 SAFETY PROCEDURES DURING USE.....	8
4.1 PRESSURE DISCHARGE OPERATIONS.....	10
4.2 ROUTINE MAINTENANCE.....	10
4.3 REPLACEMENT OF THE STUFFING BOX.....	11
4.4 TROUBLESHOOTING.....	11
WARRANTY	
GUN ASSEMBLING DRAWINGS	

HOW TO USE THE MANUAL

The following manual is a document that accompanies the machine throughout its lifetime. It is, therefore, an integral part of the machine. Carefully read the following warnings and procedures before engaging in any activity with this machine, including handling and unloading it from its transportation mean.

SYMBOLS USED

All operations which might be dangerous if not performed correctly are indicated with the

following symbol:



All operations which, in order to avoid risks, must be performed by trained and authorized personnel are indicated by the following symbol:



All personnel in charge of using the machine must be thoroughly trained; all the above information must be thoroughly understood and applied.

INFORMATION LETTER

The following maintenance and instruction manual is an integral part of the machine and must always be available to the personnel in charge of using and maintaining it. The operator and the personnel in charge of handling the machine must have knowledge of the contents of the manual. The descriptions and illustrations in the manual are not to be considered as binding. Although the main features of the machine described in this manual are not subject to change, **ASTURO ORIGINALI MAVES Spa** reserves the right to change those components, details and accessories it deems necessary to improve the machine or to meet manufacturing or commercial requirements, at any time and without updating this manual immediately.



ALL RIGHTS ARE RESERVED. The reproduction of any part of this manual, in any given form, without prior written authorization from **ASTURO ORIGINALI MAVES Spa**, is strictly forbidden. The content of this manual can be modified without prior notice. Great care has been taken in collecting and checking the documentation contained in this manual in order to make it as complete and comprehensible as possible. **ASTURO ORIGINALI MAVES Spa** machines are not designed to function in areas at risk of fires and/or explosions. For problems or information call **ASTURO ORIGINALI MAVES Spa** customer care technical service or your local dealer.

CUSTOMER CARE TECHNICAL SERVICE

ASTURO ORIGINALI MAVES Spa

Via F.lli Bandiera, 7

20090 Trezzano Sul Naviglio (MI) ITALY

TEL. ++39 0248400326 (3 linee)

FAX. ++39 0248400695

SITO: <http://space.tin.it/economia/rizierib>

E-MAIL: aomspa@tin.it



The equipment original configuration must not be modified in any way.

On receiving the equipment make sure that:

- ☞ The packaging is intact and undamaged.
- ☞ The supply corresponds to what has been ordered.
- ☞ In case of damage please call **ASTURO ORIGINALI MAVES Spa**

1.1 PACKAGING

The K90 gun is packaged in a cardboard box. All optional components are placed with the gun inside the same box. When transporting and storing the equipment make sure the surrounding temperature remains included between -15 and 40 °C (5°F and 104°F). If transportation or storage operations last 24 hours or less do not exceed 50°C (122°F) otherwise the gun could be damaged.

If the need arises to store the equipment, make sure the humidity values in the storage area remain included between 30 and 80%.

2.1 IDENTIFICATION DATA

The manufacturer identification and CE RULING n° 89/392 conformity plate is placed on a side of the gun (as shown below).

The plate must not be removed at any time, even if the equipment should be sold again.

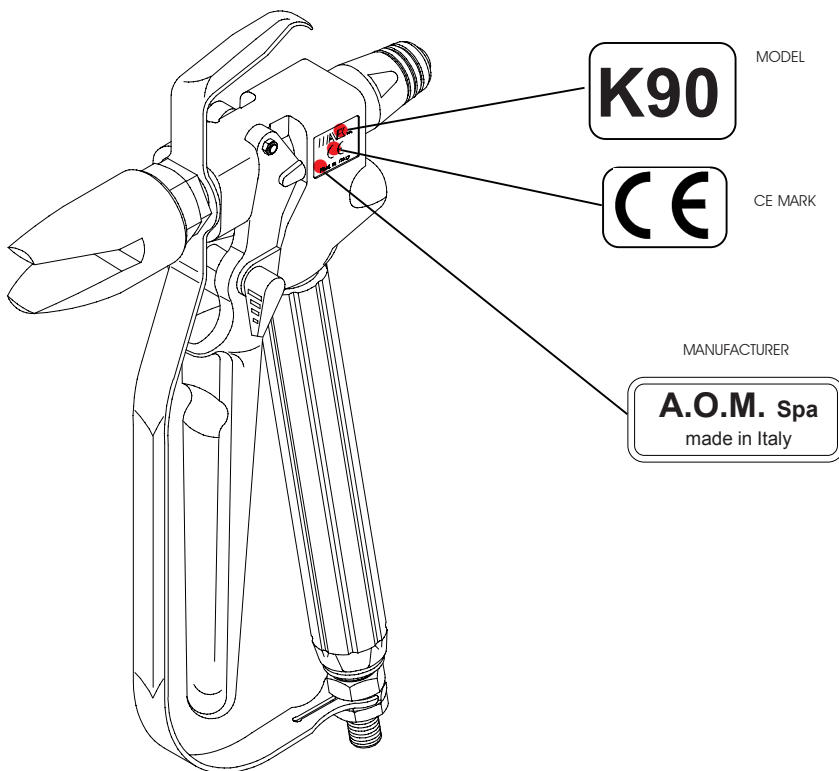

2.2 EQUIPMENT DESCRIPTION

The K90 gun is used for high painting pressures (up to 500 bar/7100psi) and to spray paints. It is possible to obtain smooth and even large-size surfaces with this gun thanks to its micro-spraying system and reduced overspray. Its main features are lightness (510 gr/ 18 oz.) and easy use. The K90 gun, coupled with a pneumatic pump unit (K30 - K45 or K25) or an electric pump (K300 - K500 - K1000 - K20000), guarantees high transfer efficiency (over 80%) and saves considerable amounts of paint. The drawing below indicates the most important features of the gun.

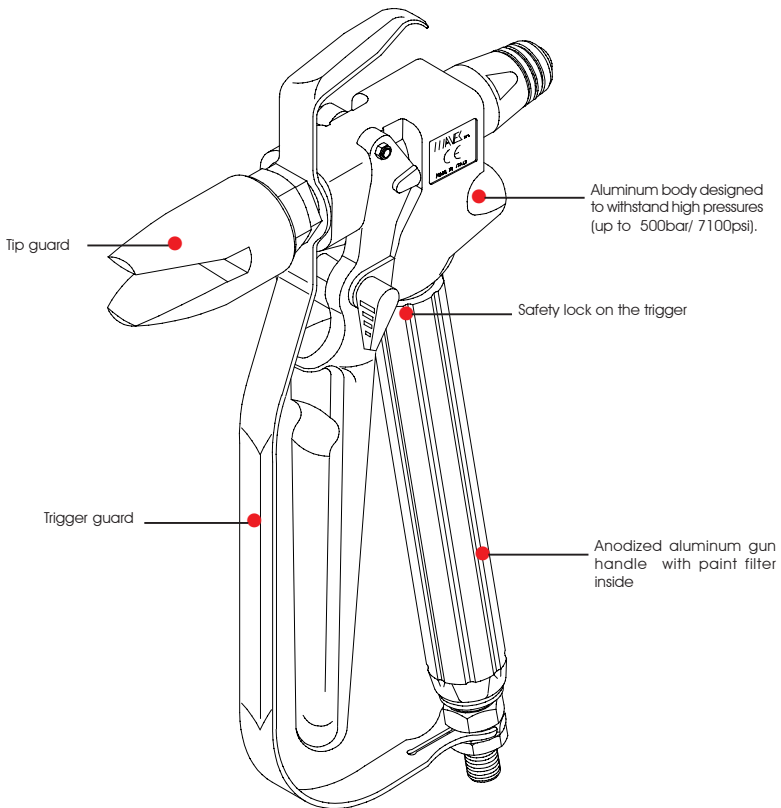

2.3 TECHNICAL FEATURES

The painting gun must be coupled with a pump with a maximum pressure of 500 bar (7100psi). **ASTURO ORIGINALI MAVES Spa** carries out all the necessary tests on the painting gun before delivering it to its customers.

NOZZLE TECHNICAL FEATURE TABLE

NOZZLE	SPRAY ANGLE	30Cm SPRAY OPENING	ORIFICE mm	ORIFICE IN INC.	PRODUCTS	FILTER	
7x20	20°	13,5	0,15	0.007"	CLEAR AND PIGMENTED LACQUER, FINE ENAMELS, STAINS	RED 200M	
7x40	40°	16,5					
9x20	20°	14	0,23	0.009"			
9x40	40°	17,5					
9x60	60°	22,5					
11x10	10°	9	0,28	0.011"			NITRE, SYNTHETIC AND POLYUTHERANE PAINTS
11x20	20°	14,5					
11x40	40°	18,5	0,33	0.013"			
13x20	20°	15,5					
13x40	40°	20					
13x60	60°	26,5	0,38	0.015"	RUST PREVENTER PAINTS		
15x20	20°	16,5					
15x40	40°	21,5	0,46	0.018"	LATEX THIXOTROPIC, SPRAY STUCCOS, FILLER PAINTS, INORGANIC ZINC, WATER PAINTS, VERY THICK PAINTS, PAINTS WITH GLUES, FILLERS	WHITE 60M	
18x10	10°	12,5					
18x20	20°	16,5	0,53	0.021"			
18x40	40°	20,5					
18x60	60°	29,5					
21x10	10°	13,5	0,66	0.026"			
21x20	20°	18,5					
21x40	40°	21,5					
21x60	60°	32,5	0,79	0.031"			
26x10	10°	15,5					
26x20	20°	22					
26x40	40°	30,5	0,94	0.037"			GREEN 30M
26x60	60°	38					
31x10	10°	15,3					
31x20	20°	22	1,04	0.041"			
31x40	40°	30,5					
31x60	60°	37,5					
41x40	40°	30,5					
41x60	60°	37,5					

The above technical features are only exemplifying and can vary without prior notice.

2.4 STANDARD AND OPTIONAL COMPONENTS

The equipment is delivered with the following standard components:

- ☞ 1 - Dismantling wrench.
- ☞ 1 - Use and maintenance manual.
- ☞ 1 - 100 ME paint filter (Yellow)
- ☞ 1 - Declaration of conformity to CE RULINGS.
- ☞ 1 - Warranty certificate.

On request:

- ☞ Nozzles of various dimensions.
- ☞ Paint filters (various meshes)
- ☞ High pressure PUMPS (various models)
- ☞ Connection hoses.
- ☞ Cleaning needles.

2.5 PAINTS, FLUIDS AND ADEQUATE PRODUCTS

The K90 guns are designed to paint on walls and on iron, wood and plastic material. The materials which can be used in the gun are: emulsion, latexsynthetic paints and enamels, polyutherane, nitre, enamels, varnishes, filler paints and water paints in general. The manufacturer must authorize the use of the gun with other products and successively the unit technical features must be changed in order to function properly with the new materials. **ASTURO ORIGINALI MAVES Spa** is relieved of all responsibility in case of accidents resulting from the use of the equipment by unauthorized and unqualified personnel or by personnel using the equipment differently than intended.

**DO NOT USE THE PAINTING SYSTEM WITH
FLAMMABLE OR HIGHLY TOXIC PRODUCTS
SUCH AS GASOLINE, HERBICIDE AND PESTICIDE**

2.6 DIMENSIONS

The gun has the following dimensions:

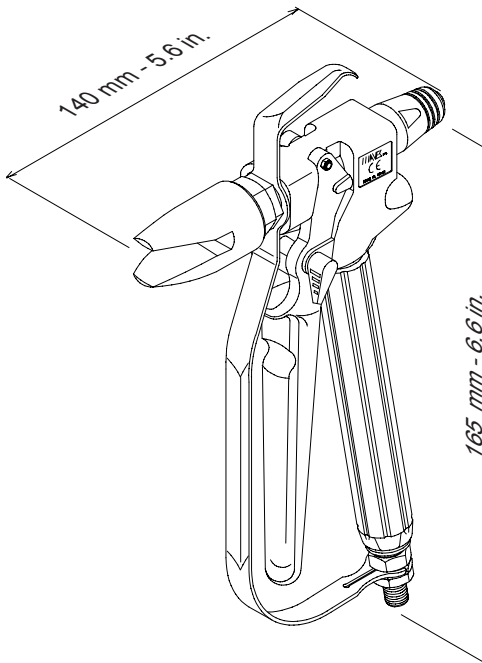

3.1 INSPECTION OF PURCHASED PRODUCT

Inspect the equipment before its use to check for damages caused by transportation or improper storage. Make sure that all standard and optional components have been delivered.

3.2 INSTALLATION CONDITIONS

The gun must be fed with a maximum pressure of 500 bar (7100psi). To mount the equipment proceed as follows (use the drawing below):

- ☞ Fasten the paint inlet hose to the gun connection (A).
- ☞ Choose which nozzles and gun filter better adapt to the operation which must be performed.

WARNING

Always use high pressure hoses to carry out all the connections. Before you start using the equipment, make sure the connections and hoses are in perfect working conditions, that is without holes, bends or splits.

WARNING

Always operate with the minimum pressure needed to obtain the results desired. Increasing pressure does not improve the painting quality, on the contrary it can wear the nozzle.

WARNING

If the spreading rate is not optimal, do not increase the paint pressure, but replace the micro-nozzle with a larger-size one.

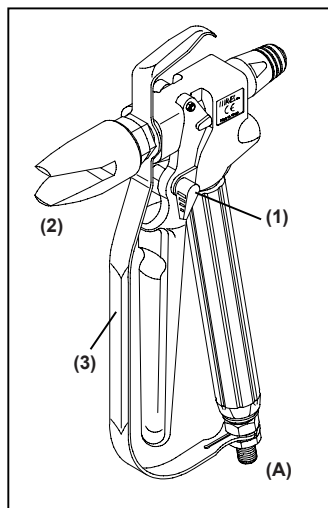

3.3 EQUIPMENT AND CONDITIONS NEEDED TO WORK







Painting operations **MUST** be carried out in an appropriate cabin equipped with a filtering system. Do not use the unit if the filtering system is not activated. Always wear protection gloves, goggles, breathing filters with active carbon and adequate clothing for the protection of the entire body. Ground all the unit components (using the given cable) because static currents could create sparks and explosions. All the equipment standard hoses are made of antistatic material.

3.5 SAFETY PROCEDURES DURING USE

TO USE the painting unit **STRICTLY OBSERVE** the following precautions and safety criteria.









ASTURO ORIGINALI MAVES Spa declines every responsibility whatsoever in case the user does not observe said precautions and safety criteria; furthermore, it is not responsible for any kind of negligence when using the equipment.

WARNING

-  Check the good functioning of the safety devices before working. The hand and the finger protections must always be mounted on the gun when operating. Always insert the safety lock placed on the trigger when interrupting the spraying, also for a short time, in order to avoid an accidental functioning of the gun. **TURN THE THROTTLE 1 COUNTERCLOCKWISE** to insert the trigger safety lock and **CLOCKWISE** to disconnect it.
-  **HAND PROTECTION 3.** Before activating the gun, mount the hand protection correctly between the sleeve and the gun body (on the upper side) and lock it to the rotating adapter on the lower side. This safety device hinders the accidental functioning of the gun in case it is hit or falls down.
-  **FINGER PROTECTION 2.** Always mount the finger protection on the gun in order to avoid putting your fingers or other part of the body accidentally in front of the gun. The finger protection must always be mounted with its packing. **IF THE NOZZLE CLOGS UP, INSERT THE TRIGGER SAFETY LOCK IMMEDIATELY. BEFORE REMOVING MATERIAL RESIDUES AROUND THE NOZZLE, COMPLETELY DISCHARGE THE PRESSURE IN THE SYSTEM.**
-  An improper use of the equipment and its components can cause serious injuries. Carefully read the technical features described in this manual and never exceed the pressure values given. Do not use worn-out or defective components, but only **ASTURO ORIGINALI MAVES** spare parts. Do not use the equipment other than originally designed. Carefully check the components and replace those worn-out or defective. The high working pressure can cause serious injections of toxic substances into the body. **IMPORTANT:** Injections must be treated by qualified medical staff as soon as possible. Inform the doctor of the paint and thinner types used.
-  **HIGH** pressure paint circulates in the hoses. Pay attention to breaks, cuts or slight leaks which can cause injections into the skin or other serious injuries. Always use high pressure hoses, check the connections before starting up the system, do not bend hoses near fittings and do not use damaged or worn-out hoses, do not attempt to repair eventual leaks. The paint flowing in the hose at a high speed causes static electricity: always check that the system is grounded.
-  Always wear protective gloves, masks, breathing filters with activated carbon and adequate clothing for the protection of the entire body.
-  The unit is employed with paints or thinners which are highly inflammable, therefore, use the machine in well ventilated areas and avoid any action which might start a fire



(eg. smoking, high temperature slags or shavings, sparks or electric elements). In order to avoid the creation of sparks due to static charges, ground the unit.

-  Always wear protective gloves, masks, breathing filters with activated carbon and adequate clothing for the protection of the entire body.
-  The unit is employed with paints or thinners which are highly inflammable, therefore, use the machine in well ventilated areas and avoid any action which might start a fire (eg. smoking, high temperature slags or shavings, sparks or electric elements). In order to avoid the creation of sparks due to static charges, ground the unit.
-  CHECK the chemical compatibility of the products on their technical safety charts. Further information on the materials which make up the unit are available, on request, at **ASTURO ORIGINALI MAVES Spa**.
-  The use of products which contain organic solvents might cause intoxication because of the created toxic vapours.
-  DO NOT USE the unit with food or medicines.
-  DO NOT EXCEED the indicated maximum working pressure (see section 2.3).
-  BEFORE starting on any dismantling, cleaning, maintenance or assembly operation DISCHARGE the pressure in the hoses (see section 4.1).
-  Never aim the gun at anything other than the surface you intend to spray.
-  NEVER put your hand or fingers in front of the nozzle.

IMPORTANT

DO NOT USE the unit with HALOGENATED HYDROCARBON thinners (eg. Ethylchloride, Trichloride, etc.) which might explode when coming into contact with aluminum or galvanized parts.

4.1 PRESSURE DISCHARGE PROCEDURES

When stopping the system to carry out operations on the unit or when stopping it at the end of the working day the high pressure inside the unit must be completely discharged. When the main air inlet is shut off, the air is automatically discharged to the pump motor.

WARNING

THE PRODUCT IN THE HIGH PRESSURE FLUID HOSE IS STILL UNDER PRESSURE.

PROCEED AS FOLLOWS:

- 1 Lock the trigger of the gun with the safety trigger lock.
- 2 Shut off the air supply to the equipment.
- 3 Unlock the safety trigger lock.
- 4 Take a metal bucket, make sure it is firmly fixed on the ground and keep the gun pressed tightly against the walls of the bucket. Pull the trigger to discharge the product.

4.2 ROUTINE MAINTENANCE

The routine maintenance of the K90 gun is simple and does not require special operations because its components do not need to be lubricated. Clean the gun daily or at the end of each working session so that product residue will not dry out on its walls, thus guaranteeing long term efficiency.

CLEANING:

Disassemble the finger protection and the micro-nozzle, the handle and thoroughly clean the filter by means of a small brush. Check that the grip packing is not worn-out, otherwise replace it. Carefully clean the micro-nozzle, dip it in thinner to dissolve residue inside it. Blow compressed air through it from the front to eliminate all traces of material. The nozzle must be mounted back on with its packing. Disassemble the diffuser and thoroughly clean with a brush, in particular the ball seat.

DO NOT USE POINTED METAL OBJECTS TO CLEAN CLOGGED ORIFICES. THESE OPERATIONS WOULD DAMAGE THEM, REDUCING THEIR SPRAYING QUALITY.

THE LUBRICANTS USED MUST NOT CONTAIN SILICONE.

WARNING

IF THE NEED ARISES CALL THE ASTURO ORIGINALI MAVES Spa CUSTOMER CARE TECHNICAL SERVICE.

4.3 REPLACEMENT OF THE NEEDLE PACKING

Completely discharge the pressure in the system, disassemble the finger protection (tip guard), the nozzle, the diffuser, the rear cap, the spring and the M3 nut. Unscrew the needle from the front side of the gun by means of a 8mm (0.31 in.) wrench. Remove the piston, unscrew the packing gland nut, pull out the pressure wedge and the stuffing box and replace it (see assembling drawing).

WARNING

When screwing the needle in the piston, make sure that the needle thread bar comes out 10mm (0.39 in.) from the piston shank, otherwise functioning problems can occur.

4.3 TROUBLESHOOTING

This chapter describes how to solve the most common problems which could affect the unit.

The problem is indicated by the following symbol: (✘)

The possible cause is indicated by the following symbol: (⇒)

The possible solution is indicated by the following symbol: (●)

✘ THE GUN SPRAYS INTERMITTENTLY

⇒ See manual of the pump used.

✘ LOW PRESSURE OF PRODUCT COMING OUT

⇒ Dirty gun filter

● Clean gun filter

✘ UNEVEN JET

⇒ Worn or dirty micro-nozzle.

● Clean the gun components carefully.

● Replace damaged parts.

✘ PAINT LEAKS OUT OF THE STUFFING BOX

⇒ Worn packing gland.

● Replace the packing gland.

✘ PAINT COMES OUT OF THE NOZZLE EVEN WHEN THE GUN IS NOT TRIGGERED

⇒ Dry paint dirties the needle ball and the diffuser ball seat.

⇒ Worn ball and ball seat.

● Clean the gun parts very carefully.

● Replace both the ball and its seat, using REPAIR KIT part Nr. 505000

WARRANTY

All **ASTURO ORIGINALI MAVES Spa** appliances are guaranteed for a period of 12 months from the date written on the invoice, unless otherwise stated in writing. The warranty covers all manufacturing faults and material defect. Replacements and repair operations are covered only if carried out by our company and at our servicing shops.

The faulty parts must be sent CARRIAGE FREE.

Once the components have been repaired they will be sent CARRIAGE PAID to the customer.

The warranty does not cover our company personnel aid during installation or dismantling operations. If for practical purposes one of our employee is sent to the premises, a charge will be made for the time plus extra for travelling and expenses.

Our warranty does not cover direct or indirect damage, to people or property, caused by our appliances and it does not cover repair operations carried out by the owner or by a third party.

The following are not covered by our warranty:

- failure caused by incorrect use or assembly.
- failure caused by external agents.
- failure caused by lack of maintenance or negligence.

WARRANTY FORFEITURE:

If the form attached below is not filled out and returned.

In case of delayed payment or other contract defaults.

All repair operations carried out under warranty do not interrupt its duration.

Whenever changes or repairs are carried out on our machinery without prior authorization

Whenever the unit seems tampered with, dismantled or previously repaired in unauthorized servicing shops.

Whenever the serial number is damaged or removed.

When the damage is caused by improper use or functioning, or if the machine falls, is bumped or by other causes of malfunctioning not due to normal working conditions

All disputes will be settled in the court of justice of Milan (Italy).



NAME: _____
COMPANY: _____
ADDRESS: _____
V.A.T. NUMBER _____
UNIT MODEL: _____
SERIAL NUMBER: _____
DATE: _____
STAMP AND SIGNATURE: _____

Send this form fully completed (capital letters) to:

ASTURO ORIGINALI MAVES Spa

Via F.lli Bandiera, 7

20090 Trezzano sul Naviglio (MI) ITALY

USE AND MAINTENANCE MANUAL



GUN ASSEMBLING DRAWING

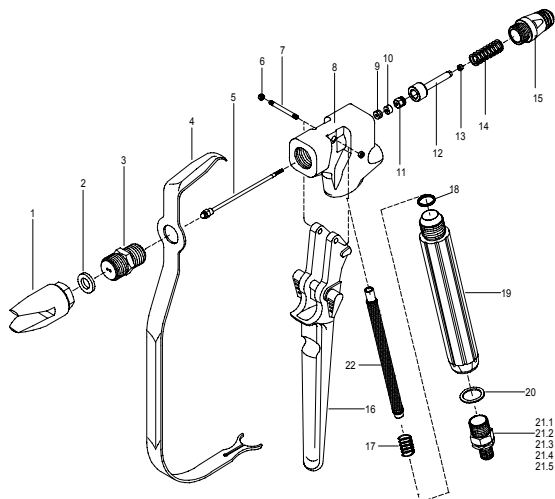

Item	CODE	Description
1	201500	FINGER PROTECTION - TIP GUARD
2	100030	ST NOZZLE PACKING
3	100031R	FLUID TIP DIFFUSER
4	108932R	TRIGGER GUARD
5	109033R	NEEDLE
6	212488	M4 SELF-LOCKING NUT
7	100044R	TRIGGER PIN
8	109034R	K90 GUN BODY
9	108956R	PRESSURE WEDGE
10	108955R	PACKING GLAND
11	108957R	PACKING GLAND SCREW
12	109038R	PRESSURE PISTON
13	100039R	M3 LOCK NUT
14	108940R	SPRING
15	109030R	REAR CAP
16	108954R	COMPLETE TRIGGER
17	301500	FILTER BEARING SPRING
18	100042R	GRIP PACKING
19	100043R	K90 GRIP
20	121418R	COPPER WASHER
21.1	107514	M 1/4" GAS SWIVEL
21.2	107515	M 1/4" NPT SWIVEL
21.3	107516	M 16x15 (0.62x0.58in.) SWIVEL
21.4	107502	M 1/2" JIC ROTATINGSWIVEL
21.5	107508R	M 1/4" NPS SWIVEL
22	303100	100ME GUN FILTER
-	100045R	19x22 (0.74x0.85 in.) WRENCH

KIT

303031 30 ME 10 GUN FILTERS KIT
 303051 50 ME 10 GUN FILTERS KIT
 303101 100 ME 10 GUN FILTERS KIT
 303201 200 ME 10 GUN FILTERS KIT

505000 K90 REPAIR KIT (3 - 5 - 9 - 10 - 11 - 13)